

品番	サイズ	D	P	d	W	H	A
SU10349-0203	20SU+30	22.22	34	W3/8	25	74	50
SU10349-0253	25SU+30	28.58	40	W3/8	25	79	50
SU10349-0303	30SU+30	34.0	46	W3/8	25	87	50
SU10349-0403	40SU+30	42.7	56	W3/8	25	96	50
SU10349-0503	50SU+30	48.6	62	W3/8	25	102	50
SU10349-0603	60SU+30	60.5	74	W3/8	25	113	50
SU10349-0753	75SU+30	76.3	88	W3/8	25	135	55
SU10349-0803	80SU+30	89.1	101	W3/8	25	145	55
SU10349-1003	100SU+30	114.3	126	W3/8	25	173	55
SU10349-1253	125SU+30	139.8	154	W1/2	30	204	65
SU10349-1503	150SU+30	165.2	182	W1/2	30	228	65
SU10349-2003	200SU+30	216.3	232	W1/2	30	280	65
SU10349-2503	250SU+30	267.4	286	W5/8	40	336	80
SU10349-3003	300SU+30	318.5	341	W5/8	40	396	90

品名 PRODUCT NAME SU管用 ELフラットUボルト 足長+30		サイズ SIZE 20SU ~ 300SU	
品番 PARTS NO. SU10349-	被覆色 COLOR AWJブルー	表面処理 SURFACE TREATMENT 電気亜鉛メッキ	
材質 A MATERIAL A エラストマー (TPE)	材質 B MATERIAL B SS400	材質 C MATERIAL C	
承認 APPROVAL	検図 CHECK	担当 IN CHARGE A.Kaneshige	製図 DRAWN 21.03.29

**AWJ** AWJ株式会社

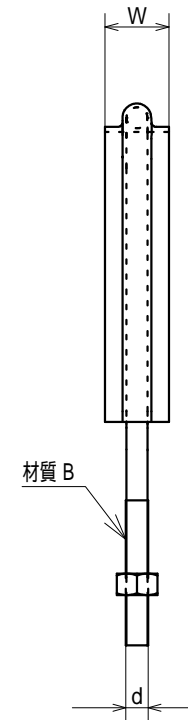
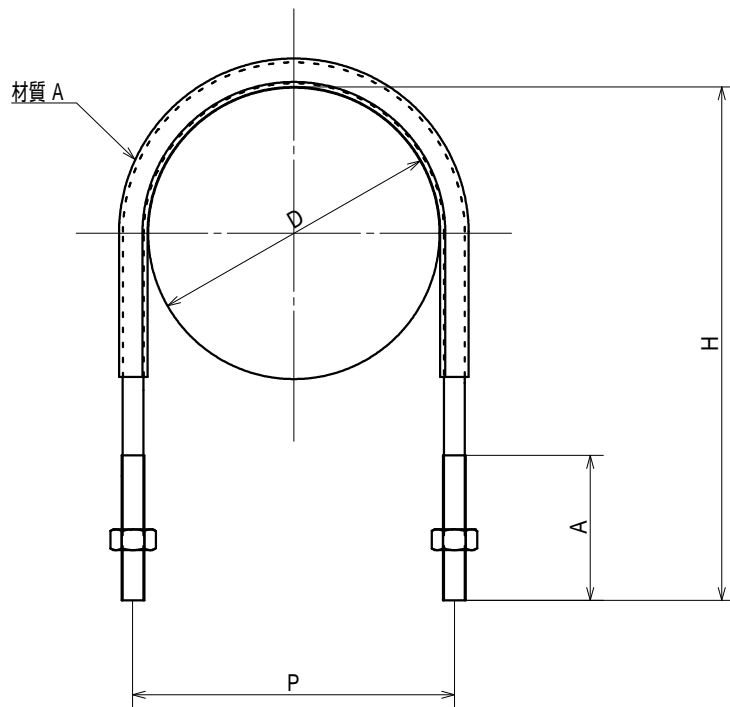

品番	サイズ	D	P	d	W	H	A
SU10349-0205	20SU+50	22.22	34	W3/8	25	94	50
SU10349-0255	25SU+50	28.58	40	W3/8	25	99	66
SU10349-0305	30SU+50	34.0	46	W3/8	25	107	66
SU10349-0405	40SU+50	42.7	56	W3/8	25	116	66
SU10349-0505	50SU+50	48.6	62	W3/8	25	122	66
SU10349-0605	60SU+50	60.5	74	W3/8	25	133	66
SU10349-0755	75SU+50	76.3	88	W3/8	25	155	66
SU10349-0805	80SU+50	89.1	101	W3/8	25	165	66
SU10349-1005	100SU+50	114.3	126	W3/8	25	193	66
SU10349-1255	125SU+50	139.8	154	W1/2	30	224	65
SU10349-1505	150SU+50	165.2	182	W1/2	30	248	65
SU10349-2005	200SU+50	216.3	232	W1/2	30	300	65
SU10349-2505	250SU+50	267.4	286	W5/8	40	356	80
SU10349-3005	300SU+50	318.5	341	W5/8	40	416	90

品名 PRODUCT NAME SU管用 ELフラットUボルト 足長+50		サイズ SIZE 20SU~300SU	
品番 PARTS NO. SU10349-	被覆色 COLOR AWJブルー	表面処理 SURFACE TREATMENT 電気亜鉛メッキ	
材質 A MATERIAL A エラストマー (TPE)	材質 B MATERIAL B SS400	材質 C MATERIAL C	
承認 APPROVAL	検図 CHECK	担当 IN CHARGE A.Kaneshige	製図 DRAWN 21.03.29

**AWJ** AWJ株式会社

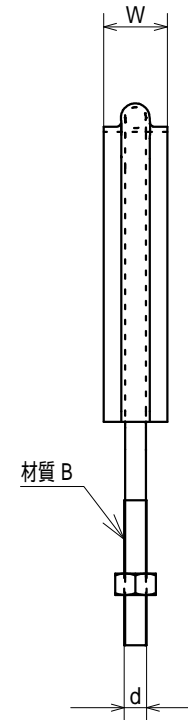
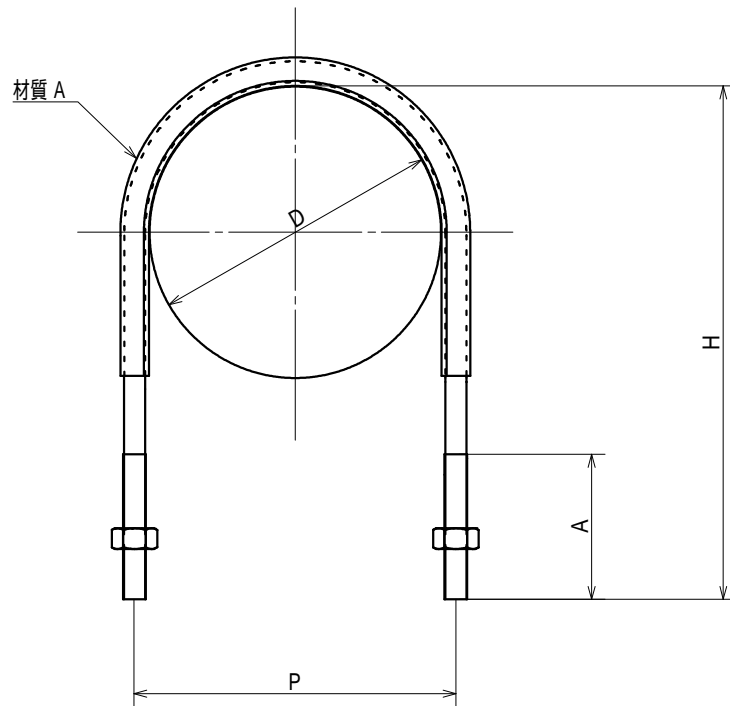

品番	サイズ	D	P	d	W	H	A
SU10350-0203	20SU+30	22.22	34	W3/8	25	74	50
SU10350-0253	25SU+30	28.58	40	W3/8	25	79	50
SU10350-0303	30SU+30	34.0	46	W3/8	25	87	50
SU10350-0403	40SU+30	42.7	56	W3/8	25	96	50
SU10350-0503	50SU+30	48.6	62	W3/8	25	102	50
SU10350-0603	60SU+30	60.5	74	W3/8	25	113	50
SU10350-0753	75SU+30	76.3	88	W3/8	25	135	55
SU10350-0803	80SU+30	89.1	101	W3/8	25	145	55
SU10350-1003	100SU+30	114.3	126	W3/8	25	173	55
SU10350-1253	125SU+30	139.8	154	W1/2	30	204	65
SU10350-1503	150SU+30	165.2	182	W1/2	30	228	65
SU10350-2003	200SU+30	216.3	232	W1/2	30	280	65
SU10350-2503	250SU+30	267.4	286	W5/8	40	336	80
SU10350-3003	300SU+30	318.5	341	W5/8	40	396	90

品名 PRODUCT NAME ステンレス SU管用 ELフラットUボルト 足長+30		サイズ SIZE 20SU ~ 300SU	
品番 PARTS NO. SU10350-	被覆色 COLOR AWJブルー	表面処理 SURFACE TREATMENT 脱脂処理	
材質 A MATERIAL A エラストマー (TPE)	材質 B MATERIAL B SUS304	材質 C MATERIAL C	
承認 APPROVAL	検図 CHECK	担当 IN CHARGE A.Kaneshige	製図 DRAWN 21.03.29

**AWJ** AWJ株式会社

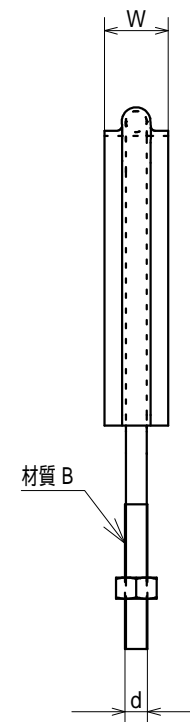
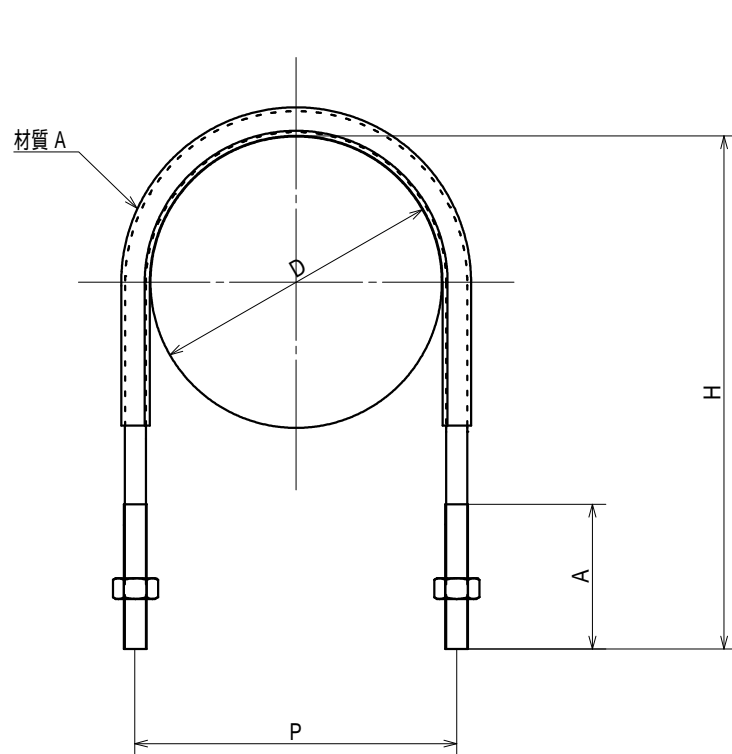

品番	サイズ	D	P	d	W	H	A
SU10350-0205	20SU+50	22.22	34	W3/8	25	94	50
SU10350-0255	25SU+50	28.58	40	W3/8	25	99	66
SU10350-0305	30SU+50	34.0	46	W3/8	25	107	66
SU10350-0405	40SU+50	42.7	56	W3/8	25	116	66
SU10350-0505	50SU+50	48.6	62	W3/8	25	122	66
SU10350-0605	60SU+50	60.5	74	W3/8	25	133	66
SU10350-0755	75SU+50	76.3	88	W3/8	25	155	66
SU10350-0805	80SU+50	89.1	101	W3/8	25	165	66
SU10350-1005	100SU+50	114.3	126	W3/8	25	193	66
SU10350-1255	125SU+50	139.8	154	W1/2	30	224	65
SU10350-1505	150SU+50	165.2	182	W1/2	30	248	65
SU10350-2005	200SU+50	216.3	232	W1/2	30	300	65
SU10350-2505	250SU+50	267.4	286	W5/8	40	356	80
SU10350-3005	300SU+50	318.5	341	W5/8	40	416	90

品名 PRODUCT NAME ステンレス SU管用 ELフラットUボルト 足長+50		サイズ SIZE 20SU ~ 300SU	
品番 PARTS NO. SU10350-	被覆色 COLOR AWJブルー	表面処理 SURFACE TREATMENT 脱脂処理	
材質 A MATERIAL A エラストマー (TPE)	材質 B MATERIAL B SUS304	材質 C MATERIAL C	
承認 APPROVAL	検図 CHECK	担当 IN CHARGE A.Kaneshige	製図 DRAWN 21.03.29

**AWJ** AWJ株式会社

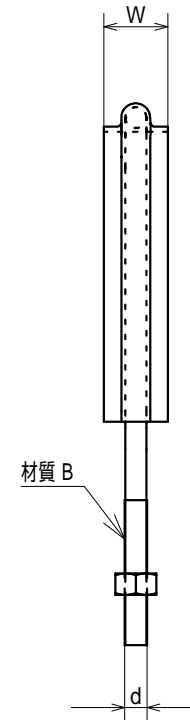
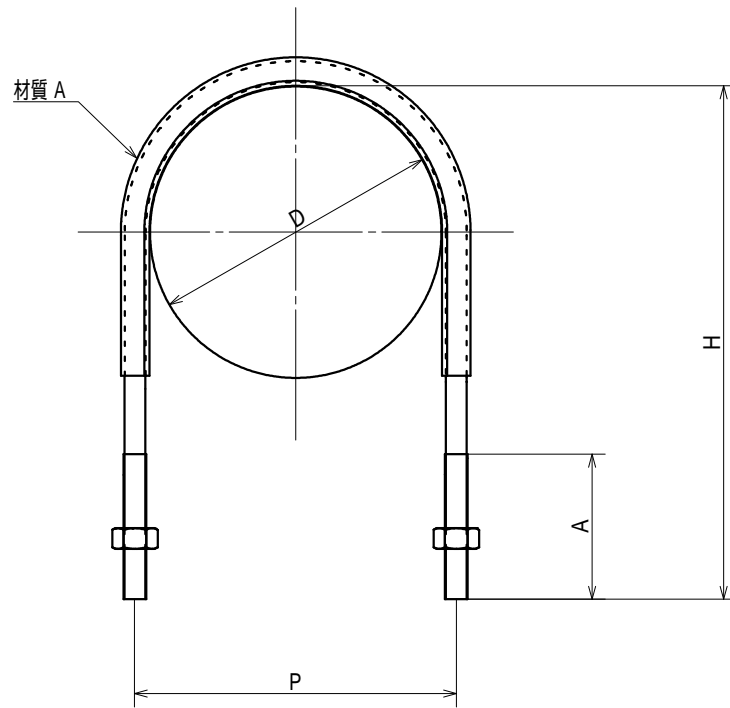

品番	サイズ	D	P	d	W	H	A
SU10359-0203	20SU+30	22.22	34	W3/8	25	74	50
SU10359-0253	25SU+30	28.58	40	W3/8	25	79	50
SU10359-0303	30SU+30	34.0	46	W3/8	25	87	50
SU10359-0403	40SU+30	42.7	56	W3/8	25	96	50
SU10359-0503	50SU+30	48.6	62	W3/8	25	102	50
SU10359-0603	60SU+30	60.5	74	W3/8	25	113	50
SU10359-0753	75SU+30	76.3	88	W3/8	25	135	55
SU10359-0803	80SU+30	89.1	101	W3/8	25	145	55
SU10359-1003	100SU+30	114.3	126	W3/8	25	173	55
SU10359-1253	125SU+30	139.8	154	W1/2	30	204	65
SU10359-1503	150SU+30	165.2	182	W1/2	30	228	65
SU10359-2003	200SU+30	216.3	232	W1/2	30	280	65
SU10359-2503	250SU+30	267.4	286	W5/8	40	336	80
SU10359-3003	300SU+30	318.5	341	W5/8	40	396	90

品名 PRODUCT NAME ドブメッキ SU管用 ELフラットUボルト 足長+30		サイズ SIZE 20SU ~ 300SU	
品番 PARTS NO. SU10359-	被覆色 COLOR ブラック	表面処理 SURFACE TREATMENT 溶融亜鉛メッキ	
材質 A MATERIAL A エラストマー (TPE)	材質 B MATERIAL B SS400	材質 C MATERIAL C	
承認 APPROVAL	検図 CHECK	担当 IN CHARGE A.Kaneshige	製図 DRAWN 21.03.29

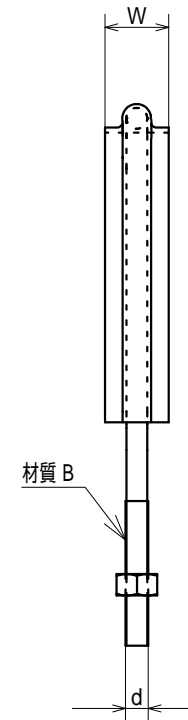
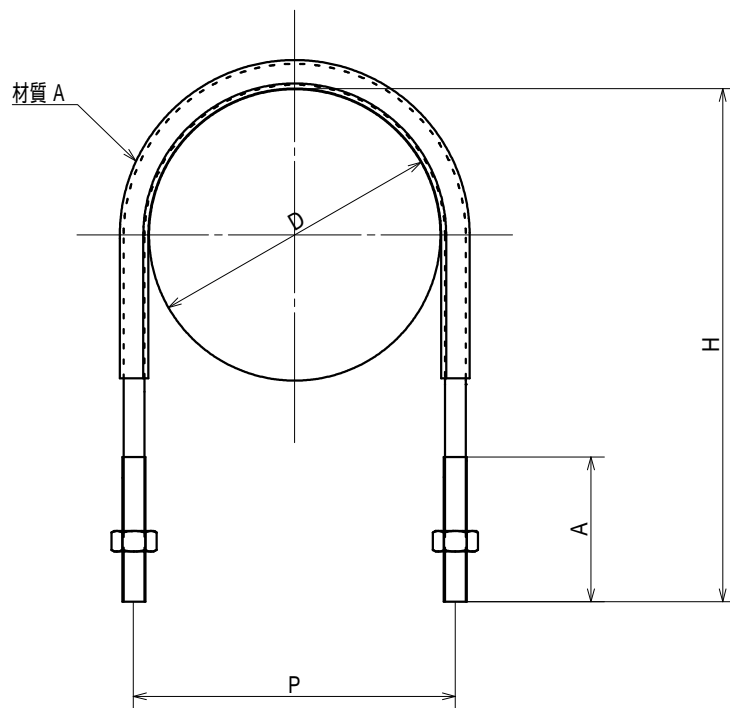

品番	サイズ	D	P	d	W	H	A
SU10359-0205	20SU+50	22.22	34	W3/8	25	94	50
SU10359-0255	25SU+50	28.58	40	W3/8	25	99	66
SU10359-0305	30SU+50	34.0	46	W3/8	25	107	66
SU10359-0405	40SU+50	42.7	56	W3/8	25	116	66
SU10359-0505	50SU+50	48.6	62	W3/8	25	122	66
SU10359-0605	60SU+50	60.5	74	W3/8	25	133	66
SU10359-0755	75SU+50	76.3	88	W3/8	25	155	66
SU10359-0805	80SU+50	89.1	101	W3/8	25	165	66
SU10359-1005	100SU+50	114.3	126	W3/8	25	193	66
SU10359-1255	125SU+50	139.8	154	W1/2	30	224	65
SU10359-1505	150SU+50	165.2	182	W1/2	30	248	65
SU10359-2005	200SU+50	216.3	232	W1/2	30	300	65
SU10359-2505	250SU+50	267.4	286	W5/8	40	356	80
SU10359-3005	300SU+50	318.5	341	W5/8	40	416	90

品名 PRODUCT NAME ドブメッキ SU管用 ELフラットUボルト 足長+50		サイズ SIZE 20SU ~ 300SU	
品番 PARTS NO. SU10359-	被覆色 COLOR ブラック	表面処理 SURFACE TREATMENT 溶融亜鉛メッキ	
材質 A MATERIAL A エラストマー (TPE)	材質 B MATERIAL B SS400	材質 C MATERIAL C	
承認 APPROVAL	検図 CHECK	担当 IN CHARGE A.Kaneshige	製図 DRAWN 21.03.29

**AWJ** AWJ株式会社

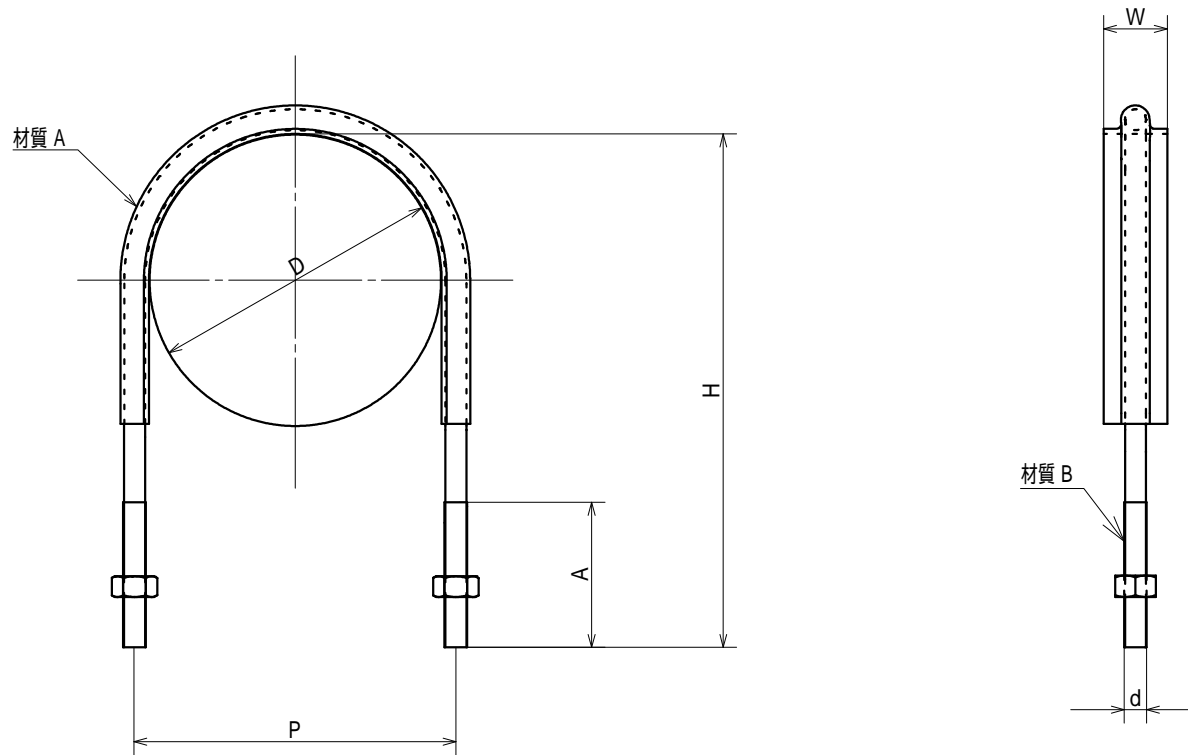

品番	サイズ	D	P	d	W	H	A
SU10354-0203	20SU+30	22.22	34	W3/8	25	74	50
SU10354-0253	25SU+30	28.58	40	W3/8	25	79	50
SU10354-0303	30SU+30	34.0	46	W3/8	25	87	50
SU10354-0403	40SU+30	42.7	56	W3/8	25	96	50
SU10354-0503	50SU+30	48.6	62	W3/8	25	102	50
SU10354-0603	60SU+30	60.5	74	W3/8	25	113	50
SU10354-0753	75SU+30	76.3	88	W3/8	25	135	55
SU10354-0803	80SU+30	89.1	101	W3/8	25	145	55
SU10354-1003	100SU+30	114.3	126	W3/8	25	173	55
SU10354-1253	125SU+30	139.8	154.0	W1/2	30	204	65
SU10354-1503	150SU+30	165.2	182.0	W1/2	30	228	65
SU10354-2003	200SU+30	216.3	232.0	W1/2	30	280	65
SU10354-2503	250SU+30	267.4	286.0	W5/8	40	336	80
SU10354-3003	300SU+30	318.5	341.0	W5/8	40	396	90

品名 PRODUCT NAME ステンレス屋外用 SU管用 ELフラットUボルト 足長+30		サイズ SIZE 20SU ~ 300SU	
品番 PARTS NO. SU10354-	被覆色 COLOR ブラック	表面処理 SURFACE TREATMENT 脱脂処理	
材質 A MATERIAL A エラストマー (TPE)	材質 B MATERIAL B SUS304	材質 C MATERIAL C	
承認 APPROVAL	検図 CHECK	担当 IN CHARGE M.Suga	製図 DRAWN 21.03.29

**AWJ** AWJ株式会社

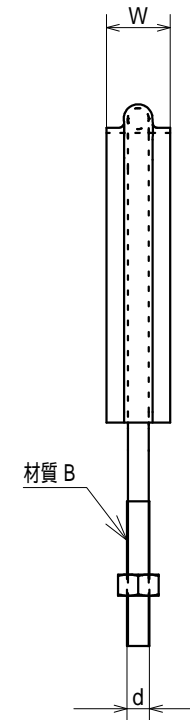
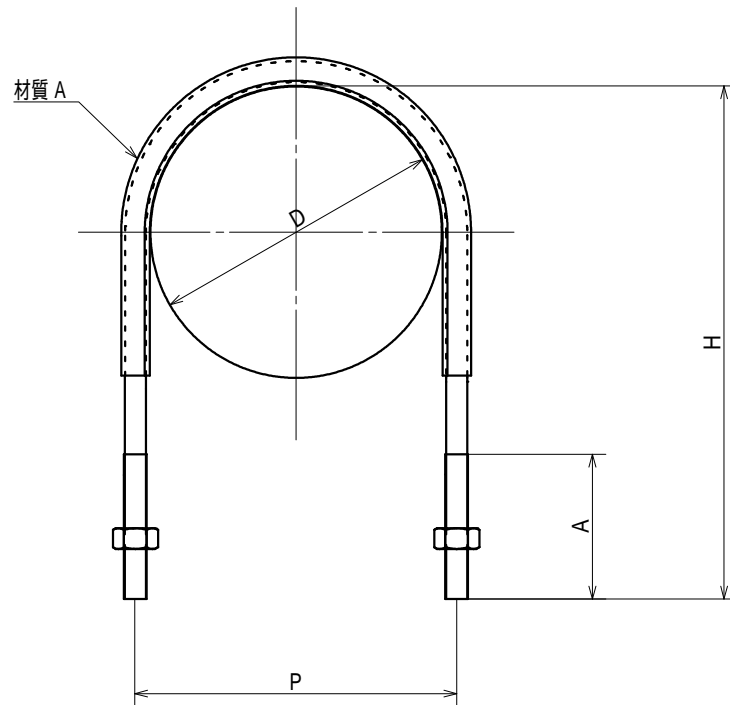

品番	サイズ	D	P	d	W	H	A
SU10354-0205	20SU+50	22.22	34	W3/8	25	94	50
SU10354-0255	25SU+50	28.58	40	W3/8	25	99	66
SU10354-0305	30SU+50	34.0	46	W3/8	25	107	66
SU10354-0405	40SU+50	42.7	56	W3/8	25	116	66
SU10354-0505	50SU+50	48.6	62	W3/8	25	122	66
SU10354-0605	60SU+50	60.5	74	W3/8	25	133	66
SU10354-0755	75SU+50	76.3	88	W3/8	25	155	66
SU10354-0805	80SU+50	89.1	101	W3/8	25	165	66
SU10354-1005	100SU+50	114.3	126	W3/8	25	193	66
SU10359-1253	125SU+50	139.8	154.0	W1/2	30	224	65
SU10359-1503	150SU+50	165.2	182.0	W1/2	30	248	65
SU10359-2003	200SU+50	216.3	232.0	W1/2	30	300	65
SU10359-2503	250SU+50	267.4	286.0	W5/8	40	356	80
SU10359-3003	300SU+50	318.5	341.0	W5/8	40	416	90

品名 PRODUCT NAME ステンレス屋外用 SU管用 ELフラットUボルト 足長+50		サイズ SIZE 20SU ~ 300SU	
品番 PARTS NO. SU10354-	被覆色 COLOR ブラック	表面処理 SURFACE TREATMENT 脱脂処理	
材質 A MATERIAL A エラストマー (TPE)	材質 B MATERIAL B SUS304	材質 C MATERIAL C	
承認 APPROVAL	検図 CHECK	担当 IN CHARGE M.Suga	製図 DRAWN 21.03.29

**AWJ** AWJ株式会社